



Consultation and demonstration

If you would like advice or would like to see products before making a purchase decision, one of our medical device advisors will be happy to come to you.



utila Gerätebau GmbH + Co. KG
Zobelweg 9
53842 Troisdorf

Telefon +49 2241 9483 0
Fax +49 2241 9483 25

info@utila.de
www.utila.de

CONTENT	PAGE
---------	------

PATIENT TRANSPORT



Carrying Chair ALS 118 / ALS 128	4-5
Carrying Chair ALS 318 / ALS 328	6-7
Carrying Chair ALS 318 PTX / ALS 328 PTX	11
Carrying Chair ALS 328 F / ALS 328 F-PT	14-15
Carrying Chair ALS 428	16
Carrying Chair/Seat Combination BTS 918	17



Floor Fastener BH 501 E	13
Wall Fixation WH-PTX	13
Charger / Battery	13
Wall Fixation WH 918	17
Backrest Padding RTP 318 / RTP 318 PT	18
Shoulder Harness / Leg Restraint and Patient Restraint	18



Swivel Wheels MP-S 1	18
Floor Fastener BH 501 M	19
Retrofit-Kits PTX	19



Patient Rain Protection PU	25
----------------------------	----

RESCUE PRODUCTS



Rescue Carrying Sheet 4028 EN	24
Heavy Duty Carrying Sheet 4028 XL	24
Heavy Duty Carrying Sheet 4028 XL-F	24



X-Frame Stretcher Transporter 2018 R	26-29
2018 RH / 2018 RE / 2018 REH X-Frame Stretcher Transporter	31-34
X-Frame Stretcher Transporter equipment	35-39



Aluminum frame white powder coated, other RAL colours possible.
 All products in this catalog are medical devices.
 All information is subject to change.

PATIENT TRANSPORT

ALS 118
ALS 128



Classic Chair made to latest EN specifications: Carrying Chairs ALS 118 / ALS 128

Our popular carrying chairs have been modified to meet the current EN-specifications. This guarantees security and safety for patient and operators.

Patients can be transported in this chair in seating position inside the ambulance.

Standard features:

- welded aluminum frame construction
- white powder coating, at additional cost other RAL colors possible
- telescoping carrying handles at front and rear end
- additional folding handles at back
- folding armrests
- telescoping footrest
- two 150 mm rear swivel wheels with brake and directional lock
- two 150 mm stationary front wheels
- anatomic back and seat padding, black
- two patient restraints in blue, with push button, optional restraints available in black or red
- lock pins for floor fastener BH 501 E or BH 501 M

Available versions:

ALS 118 with 500 mm seat height
ALS 128 with 10 mm height-kit

Accessories:

Floor Fastener BH 501 E, with electrical release
Floor Fastener BH 501 M, with manual release
Shoulder Harness

Important:

Carrying chairs ALS 118 and ALS 128 are tested to latest EN specifications in combination with floor fastener BH 501 E and BH 501 M.



Telescoping rear handles with anti slip plastic coating.

**Classic utila Chair
with high seating comfort !**

PATIENT TRANSPORT

Features:

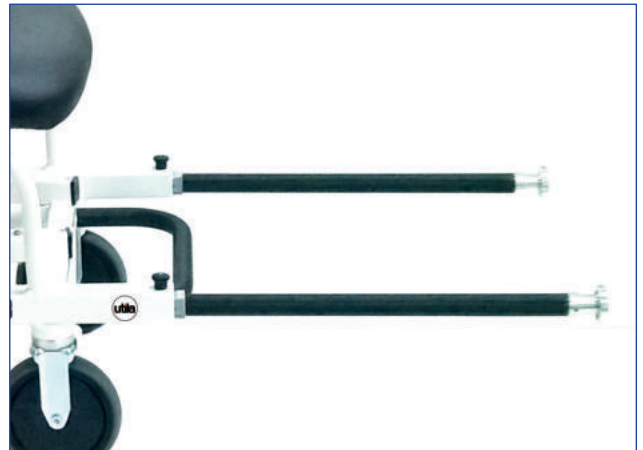
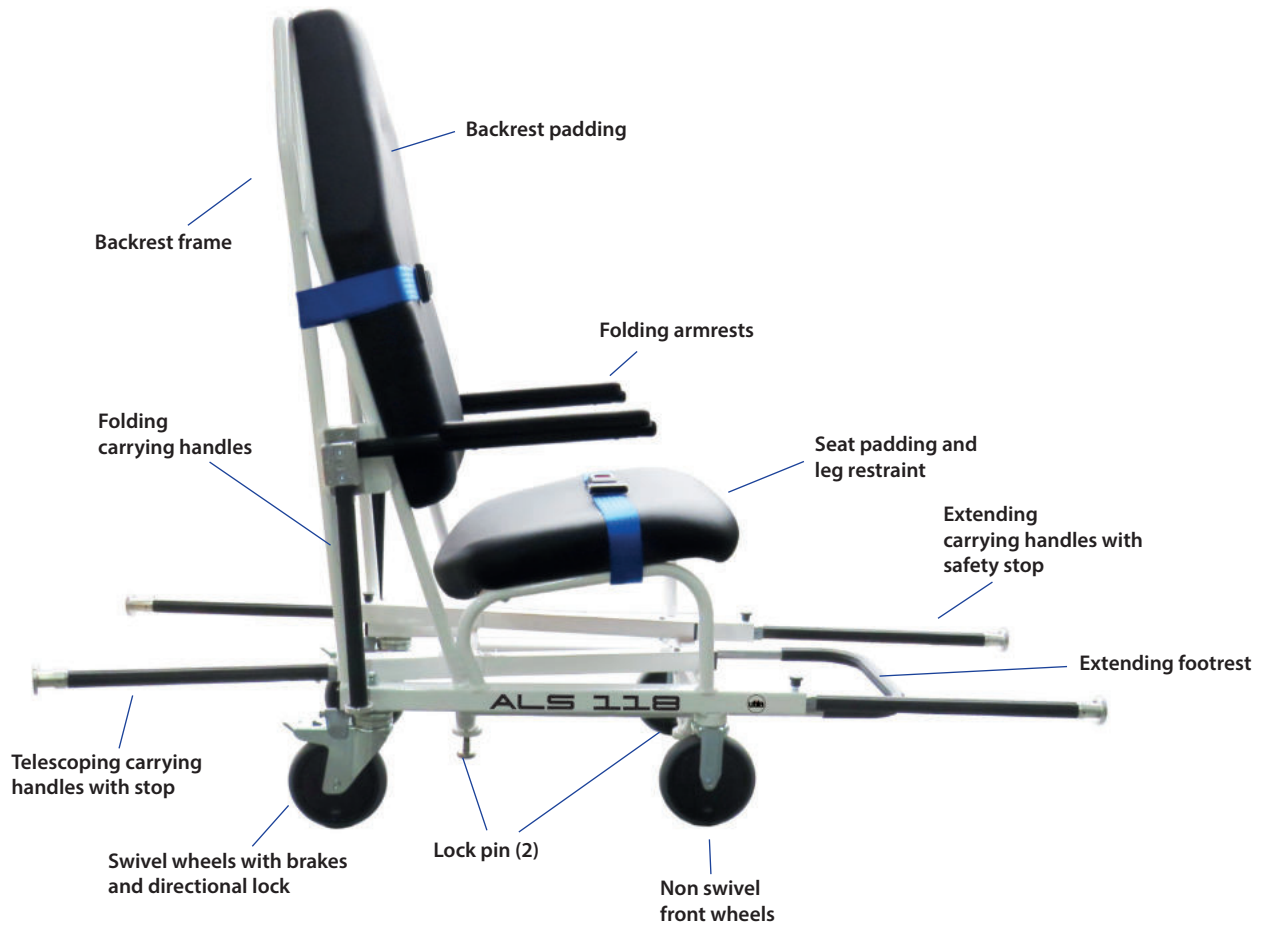

SPECIFICATIONS

	Length handles extended	Length handles retracted	Width	Height	Seat height	Weight	Load capacity max.
ALS 118	1 600 mm	800 mm	570 mm	1 230 mm	500 mm	24.5 kg	150 kg
ALS 128	1 600 mm	800 mm	570 mm	1 240 mm	510 mm	24.5 kg	150 kg

PATIENT TRANSPORT

ALS 318

ALS 328

Lightweight made to latest EN-regulations: Carrying Chairs ALS 318 / ALS 328

This chair is similar to our standard classic model but weighs only 18.5 kg. Therefore, it is easy to handle though it is strong and stable.

In combination with the floor fastener BH 501 E patients can be transported in this chair in seating position inside the ambulance.

Standard features:

- welded lightweight aluminum frame construction
- white powder coating, at additional cost other RAL colors possible
- two rear folding handles with anti slip plastic coating, two front telescoping handles with anti slip plastic coating
- folding armrests
- folding footrest with anti slip plastic coating
- two 150 mm fixed front wheels, and two 150 mm rear swivel wheels with brake (optional directional wheel lock)
- integrated headrest
- welded seat padding with slots for shoulder harness, black
- 4-point restraint system and leg restraint in black, optional restraint in blue or red available
- lock pins for floor fastener BH 501 E or BH 501 M

Available versions:

ALS 318 with 450 mm seat height
ALS 328 with 10 mm height-kit

Both models are available with directional locks on rear swivel wheels.

Accessories:

Floor Fastener BH 501 E, with electrical release
Floor Fastener BH 501 M, with mechanical release

Important:

Carrying chairs ALS 318 and ALS 328 are tested to latest EN specifications in combination with floor fastener BH 501 E and BH 501 M.



10 mm height-kit on model ALS 328

**Solid aluminum construction
with only 18.5 kg weight !**

PATIENT TRANSPORT

Features:



SPECIFICATIONS

	Length handles extended	Length handles retracted	Width	Height	Seat height	Weight	Load capacity max.
ALS 318	1 420 mm	760 mm	570 mm	1 230 mm	450 mm	18.5 kg	150 kg
ALS 328	1 420 mm	760 mm	570 mm	1 240 mm	460 mm	18.5 kg	150 kg

SOME LIKE IT COLORFUL



We bring color into the game

Unlike Henry Ford back then, a utila carrying chair cannot be ordered in just one color. The customer can choose one of the many RAL colors.



Individual labeling

is also possible for a small surcharge.



PATIENT TRANSPORT

Universal:
Electro ⚡ mobility
for Patient Transport!

With the Electric PowerTraxx™
 Upstairs **and** Downstairs, just Push the Button.

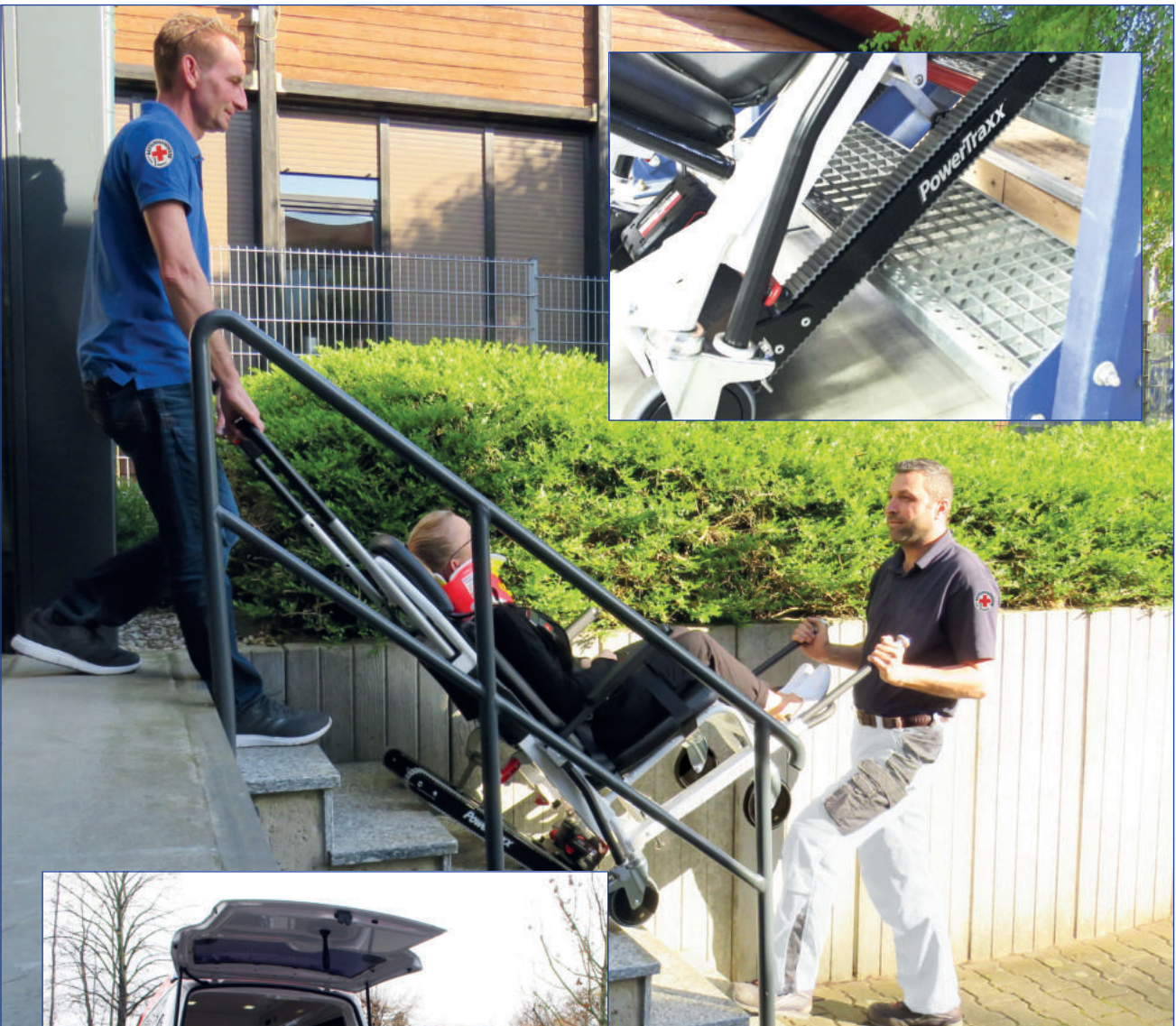

Important:
 The standard restraints on utila carrying chairs are only for securing the patient during transport outside the ambulance. During transportation in the ambulance please use vehicle mounted safety restraints following your national rules and regulations.

Patients can be transported in ALS carrying chairs in seating position inside the ambulance in combination with floor fastener BH 501 E or BH 501 M.



ALS 318 PTX

ALS 328 PTX

Fully on trend: PowerTraxx Carrying Chairs ALS 318 PTX / ALS 328 PTX

With the utila ALS 318 PTX carrying chair, electrification is also finding its way into patient transport. However, not for environmental reasons, because our chairs were already almost 100% recyclable when that wasn't an issue. In our case, it's more about reducing workload and making daily work easier.

Based on the basic ALS 318 model, the PTX is equipped with the removable, electrically powered PowerTraxx system. The PowerTraxx system is folded out with one hand. At the push of a button, the user determines whether to go up or down stairs. The special thing about this chair is the small but powerful electric motor that drives the PowerTraxx system. With a charged battery, up to 800 steps can be overcome with a patient weighing around 110 kg.

The stair gliding function is also possible downwards without a motor, so no lifting is necessary.

Easy maneuverability even in the tightest of spaces thanks to swiveling castors at the front and a guide bar that can be adjusted to 4 positions.

The Milwaukee® battery is easy to change. The charger with 220 V electrical connection is also suitable for installation in the vehicle (with voltage converter).

With the carrying chair in conjunction with the floor mount BH 501 E or BH 501 M, patients can be transported in a sitting position in the vehicle.



PowerTraxx Upstairs & Downstairs

The Original.

PATIENT TRANSPORT

If the electric PowerTraxx system cannot be used due to local conditions, you can simply remove the PowerTraxx system and click it back onto the chair when needed. In the vehicle, the PowerTraxx system can be safely stored in the WH-PTX wall bracket.

Standard features:
as ALS 318 / ALS 328

Available Versions:
ALS 318 PTX with 500 mm seat height
ALS 328 PTX with 10 mm height-kit

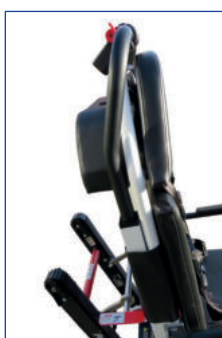

Ergonomic handlebar FB-PT

The ergonomic handlebar can also be purchased as a spare or replacement part and subsequently installed on the utila carrying chairs ALS 318/328 PTX.

SPECIFICATIONS

	Length handles extended	Length handles retracted	Width	Height	Seat height	Weight	Load capacity max.
ALS 318/328 PTX	1 420 mm	860 mm	570 mm	1 240 / 1 250 mm	450 / 460 mm	36.6 kg	150 kg
	Height	Width	Depth	Weight without battery pack			
PTX	740 mm	390 mm	125 mm	12 kg			

PATIENT TRANSPORT

Features:



Control panel

Extending lead handle

Release lever for height adjustment

PowerTraxx unlock bar

PowerTraxx lock lever

Folding carrying handles with stop

Tracks

Battery

Wheels with break

Lock pin (2)

Folding armrests

Seat padding and leg restraint

Extending carrying handles with safety stop

Folding footrest

Swivel wheel

Backrest padding and shoulder harness

Accessory:
Floor fastener BH 501 E

Safe, comfortable patient transport over stairs, reducing back injuries.

That's  how it works today

Accessories:

Floor mount BH 501 E, with electrical release
Floor mount BH 501 M, with mechanical release
Wall mount WH-PTX for PowerTraxx system

Attention:

The ALS 318 PTX and ALS 328 PTX carrying chairs have been checked and tested in conjunction with the BH 501 E and BH 501 M floor mounts in accordance with applicable standards and regulations. - The carrying chairs with PowerTraxx system must not be used one after the other in the vehicle.

PATIENT TRANSPORT

Floor Fastener BH 501 E

BH 501 E

This fastener can be used with all utila carrying chairs except model BTS 918.

Standard features:

- stainless steel housing components
- automatic locking when loading chair into fastener
- electric and manual release button
- plastic protection for lock pins



20 g Crashtest!



Wall Fixation WH-PTX

Wall fixation for securing detachable PowerTraxx system of carrying chair ALS 318 PTX or ALS 328 PTX in the ambulance.

10 g Crashtest!



Charger/Battery



Milwaukee® charger and battery

ALS 328 F

Airport Carrying Chair ALS 328 F

This chair is the small version of model ALS 328 to fit into the narrow aisle of an airplane. The chair weighs only 18.5 kg and is easy to handle.

Patients can be transported in this chair in seating position inside the ambulance in combination with floor fastener BH 501 E or BH 501 M.

**Safe, comfortable
patient transport over stairs,
reducing back injuries.**



Standard features:

- welded lightweight aluminum frame construction
- white powder coating, at additional cost other RAL colors possible
- two telescoping front handles with safety stop, two folding rear handles (two attachable rear handles on PT-version), all handles with anti slip coating
- folding footrest with anti slip aluminum plate
- two 150 mm front swivel wheels, and two 150 mm rear swivel wheels with brake (optional directional wheel lock)
- PT-version with two fixed rear wheels and two front swivel wheels with brake
- integrated headrest
- welded seat padding, black
- 4-point restraint system and leg restraint standard in red, also available in black or blue
- lock pins for floor fastener BH 501 E or BH 501 M

Available versions:

- ALS 388 F without PowerTraxx
- ALS 328 F-PT with fixed PowerTraxx

Accessories:

- Floor Fastener BH 501 E, with electrical release
- Floor Fastener BH 501 M, with mechanical release

Important:

Carrying chairs ALS 328 F and ALS 328 F-PT are tested to latest EN specifications in combination with floor fastener BH 501 E and BH 501 M.

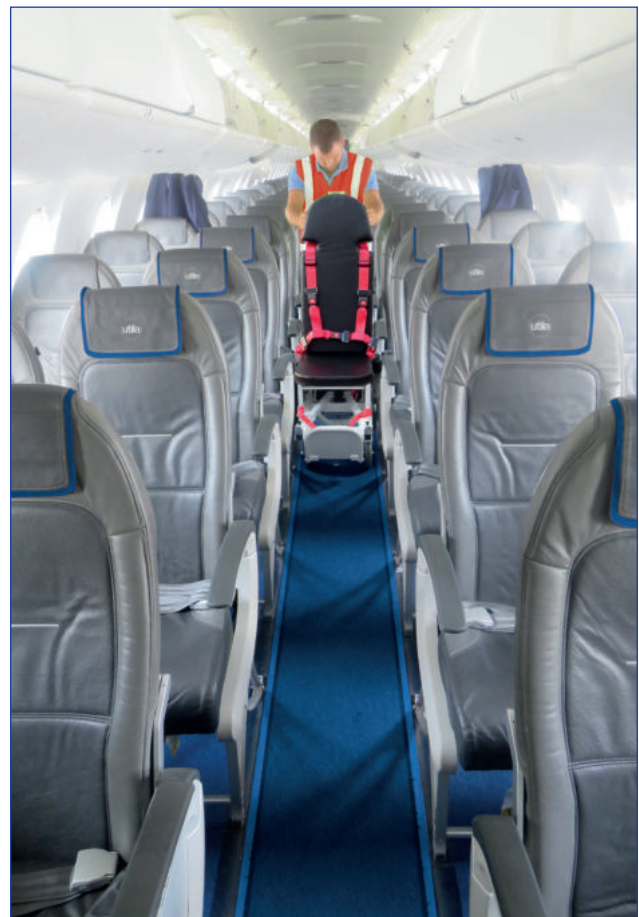

PATIENT TRANSPORT

ALS 328 F-PT



Carrying chairs with PT may not be used in a row inside the ambulance .

Airport Carrying Chair ALS 328 F-PT with PowerTraxx

Standard Airport Chair ALS 328 F equipped with PowerTraxx system. Just push a button for going up or down the stairway.

Patients can be transported in this chair in seating position inside the ambulance in combination with floor fastener BH 501 E or BH 501 M.



SPECIFICATIONS

	Length handles extended	Length handles retracted	Width	Height	Seat height	Weight	Load capacity max.
ALS 328 F	1 450 mm	800 mm	370 mm	1 230 mm	460 mm	18.5 kg	150 kg
ALS 328 F-PT	1 640 mm	850 mm	370 mm	1 230 mm	460 mm	36.0 kg	150 kg

ALS 428



NEW: Secured lying position

Carrying Chair ALS 428

The carrying chair ALS 428 is foldable for space saving storage inside the ambulance. For patient comfort or patient treatment outside the ambulance, the carrying chair ALS 428 can be secured in a lying position. The lying position is not to be used for transportation inside the ambulance.

Standard features:

- welded lightweight aluminum frame construction
- white powder coating, at additional cost other RAL colors possible
- two front and two rear telescoping handles with anti slip plastic coating and safety stop, two rear folding handles with anti slip plastic coating
- folding armrests
- folding footrest with anti slip plastic coating
- two 150 mm fixed front wheels, and two 150 mm rear swivel wheels with brakes (optional directional wheel lock)
- integrated headrest
- welded seat padding, black
- 4-point restraint system and leg restraint standard in blue, also available in black or red
- lock pins for floor fastener BH 501 E or BH 501 M

Accessories:

Floor Fastener BH 501 E, with electrical release
 Floor Fastener BH 501 M, with mechanical release

Important:

Carrying chair ALS 428 is tested and approved in combination with floor fastener BH 501 E and BH 501 M.

NEW! Patients can be transported in this chair in seating position inside the ambulance in combination with floor fastener BH 501 E or BH 501 M. No patient transfer necessary.

The folded chair can also be stored in the BH 501 E or M fastener at the wall of the ambulance or an equipment compartment.

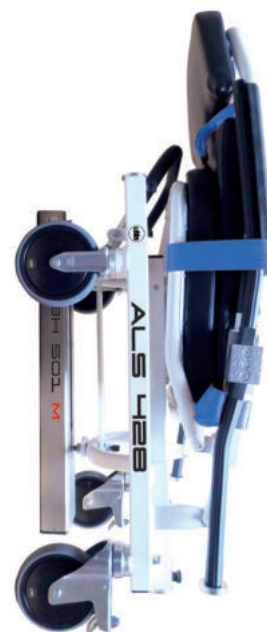

Safety locks prevent telescoping handles from slipping out when chair is folded

SPECIFICATIONS

	Length handles ext.	Length ready to use	Length folded	Width	Height ready to use	Height folded	Seat height	Weight	Load capacity max.
ALS 428	1 610 mm	820 mm	1 100 mm	580 mm	1 240 mm	450 mm	480 mm	23.5 kg	150 kg

BTS 918



Carrying Chair / Seat Combination BTS 918

The carrying chair / seat combination BTS 918 was developed because of the limited space available inside the ambulance.

Outside the vehicle, the carrying chair / seat combination BTS 918 is used in the usual way to transport patients and to bring them to the vehicle.

NEW! Inside the vehicle, the carrying chair / seat combination BTS 918 can be used as a caretaker seat in front of the stretcher or for transporting patients in seated position.

With the locking axis at the back of the backrest frame, the folded or unfolded carrying chair / seat combination BTS 918 is securely locked in the optional available wall fastener WH 918.

Is the carrying chair / seat combination BTS 918 not needed, it can be folded to save space.

Standard features:

- welded lightweight aluminum frame construction
- white powder coating, at additional cost other RAL colors possible
- two front telescoping handles with anti slip plastic coating and safety stop, two rear folding handles with anti slip plastic coating
- folding armrests
- folding footrest with anti slip plastic coating
- two 150 mm fixed front wheels, and two 150 mm rear swivel wheels with brakes (optional directional wheel lock)
- integrated headrest
- welded seat padding, black
- 4-point restraint system and leg restraint standard in blue, also available in black or red

Wall fastener WH 918

The wall fastener WH 918 has been especially designed to securely lock the carrying chair / seat combination BTS 918 inside the vehicle during transport.

The locking axis on the back frame of the carrying chair / seat combination BTS 918 is locked in the wall fastener. To release the carrying chair / seat combination BTS 918, simply pull the sheathed cable up a little.

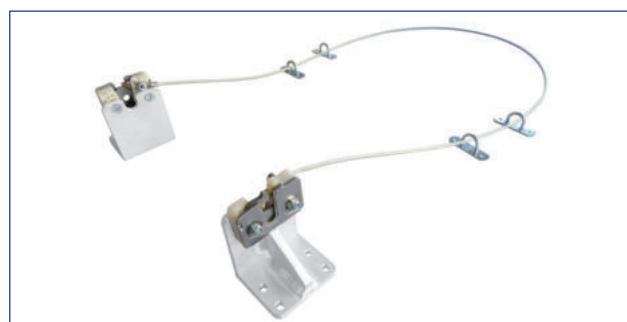

SPECIFICATIONS

	Length handles extended	Length ready to use	Height folded	Width	Height	Seat height	Weight	Load capacity max.
BTS 918	930 mm	600 mm	340 mm	560 mm	1 320 mm	530 mm	17 kg	150 kg

ACCESSORIES

Backrest Padding RTP 318

Additional padding mounted to the upper frame, for ALS 318 and ALS 328.



Backrest Padding RTP 318 PT

Like RTP 318, but for carrying chairs PTX.



Additional Swivel Wheels MP-S 1

Two swivel wheels instead of stationary front wheels, without brake, without directional wheel lock. Available for all standard versions as option, standard on chairs with track system.



Ergonomic handlebar FB-PT

When purchasing a utila ALS 318/328 PTX chair, you have the option of choosing between the regular and the new ergonomic handlebar.

With the ergonomic handlebar, it is even more comfortable for the operator on the head part of the carrying chair to hold the carrying chair safely in the tilted state, when driving down and / or up stairs.

The ergonomic handlebar can also be purchased as a spare or replacement part and subsequently installed on the utila carrying chairs ALS 318/328 PTX.

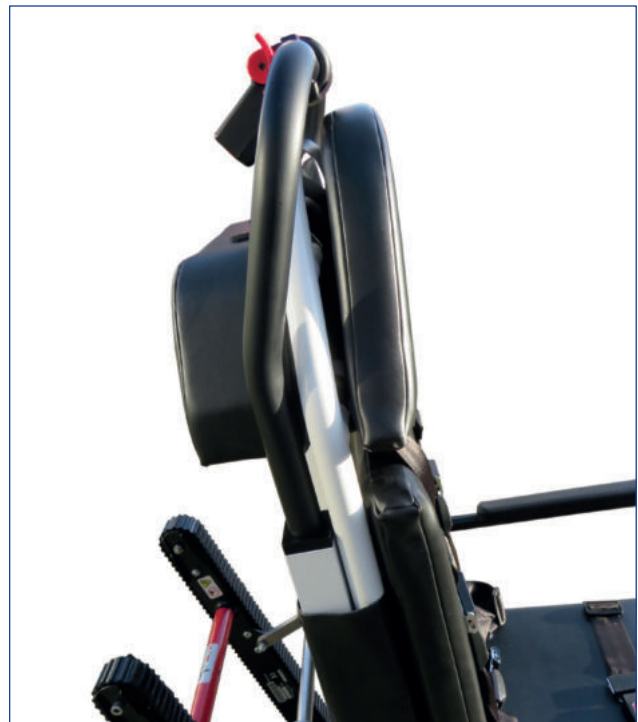

Patient Restraint two-piece style

with push button, black, blue or red

black	410140
blue	410144
red	410145

Patient Restraint one-piece style

with push button, black, blue or red

black	410141
blue	410146
red	410147

Shoulder Harness / Leg Restraint

The shoulder harness / leg restraint is optional available for all utila carrying chairs.

black	0312360
blue	0312361
red	0312362

Two-part, one-part restraints and the shoulder harness / leg restraint are available in black, blue or red.



Patient restraint 410140, two-piece style

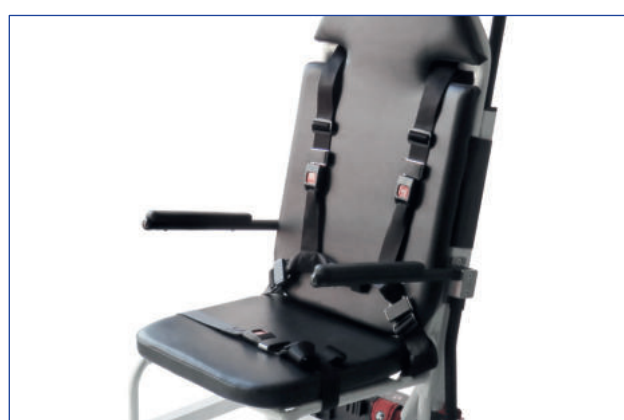

Shoulder harness 0312360 and patient restraint 410141

Floor Fastener BH 501 M

This fastener can be used with all utila carrying chairs except model BTS 918.

Standard features:

- stainless steel housing components
- automatic locking when loading chair into fastener
- manual release button
- plastic protection for lock pins

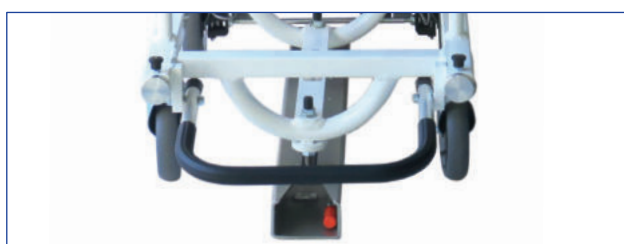

Floor fastener for all utila chairs, except BTS 918

Retrofit-Kits PowerTraxx PTX

Available for standard versions of ALS 318 / ALS 328 chairs without tracks.



SAFETY FOR OPERATOR AND PATIENT

TÜV Rheinland tested and approved

utila Carrying Chairs are Medical Devices and have to undergo strong tests to conform to the current regulations in the EU. The new chairs are tested according to EN 1789:2007+A2:2014, Rescue service vehicles and their equipment - ambulances; section 4.5.9 checking the holding systems and attaching the equipment in an ambulance.

Tested according to UN Regulation 17/08 - Resistance of the seat anchor and the adjustment, locking and adjustment devices „20g/30ms“.

utila Carrying Chairs are made from aluminum, a light-weight and solid construction. The maximum load capacity is 150 kg. Seat paddings are welded, easy to clean and resistant against disinfection fluids. Standard padding colour is black.

All utila Carrying Chairs (except BTS 918) are equipped with two strike pins to lock into Floor Fixation BH 501 E or BH 501 M and are only tested in combination with these fixations.

Please see following safety instruction!

The standard restraints on utila Carrying Chairs are only for securing the patient during transport outside the ambulance.

During transportation in the ambulance please use vehicle mounted safety restraints following your national rules and regulations.





Crash-Test

utila Carrying Chairs Models ALS 118 / 128 and ALS 318 / 328, and also the PTX versions are tested in combination with the utila Floor Fastener BH 501 M and BH 501 E.

Also tested: Wall Fixation WH-PTX.

SAFETY FOR OPERATOR AND PATIENT



**10 G / 20 G -
sounds hard ...
... what utila chairs have to undergo.**

**Crash forward, backward,
from the side and
turn over of the ambulance
are simulated and tested.**

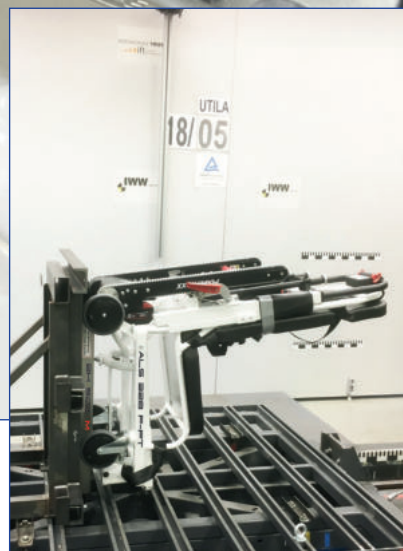

SAFETY FOR OPERATOR AND PATIENT

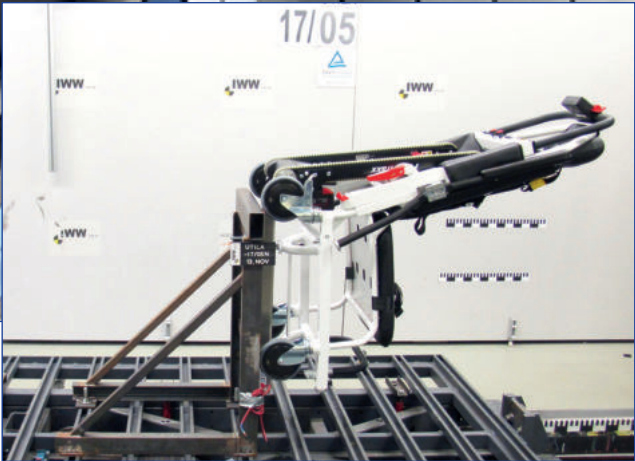
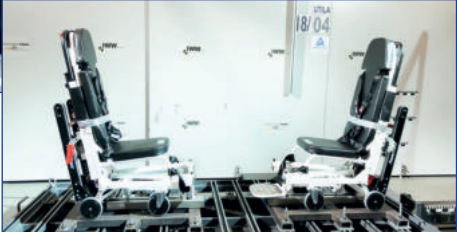

RESCUE AND EVACUATION

Rescue Sheet 4028 EN

Strong PVC-material with 6 carrying handles. For use in narrow stair cases or rough territory.

Accessory: carry case 4029



Heavy Duty Rescue Sheet 4028 XL

Strong PVC-material with 24 carrying handles. For use in narrow stair cases or rough terrain. Specially designed for bariatric persons.

Standard: protection bag



Heavy Duty Rescue Sheet 4028 XL-F

Strong PVC-material with 14 carrying handles. For use in narrow stair cases or rough terrain. Specially designed for bariatric persons.

A foot pocket prevents patient from slipping out of rescue sheet during transport over stairs or uneven terrain.

Standard: protection bag



SPECIFICATIONS

	Length	Width	Height	Weight	Load capacity max.
4028 EN	1 950 mm	700 mm	5 mm	1.3 kg	250 kg
4028 XL	2 580 mm	1 400 mm	7 mm	3.5 kg	350 kg
4028 XL-F	2 580 mm	1 400 mm	10 mm	4.5 kg	350 kg

PATIENT TRANSPORT

Patient Rain Protection PU

Bacteriostatic patient rain protection, especially for seated patients. Suitable for all utila and Ferno chairs.

The temperature is absorbed and maintained by thermal fibers inside. In this way, the patient can be transported warm on cold days, dry on rainy days, and always comfortably even during long journeys.

The integrated hood also keeps the patient's head warm and protected from wind, rain and snow.

The zipper is waterproof and allows the patient's rain protection to be opened completely.

The patient rain protection made of coated polyester is water-repellent, breathable, soft and comfortable and easy to carry with a weight of approx. 1.2 kg. It corresponds to fire resistance class M1 and can easily be disinfected with decontamination spray and wipes or washed in the washing machine up to 95 °C.



Waterproof zipper



Cleaning in the washing machine up to 95 °C

SPECIFICATIONS

	width	length	color	weight
Patients Rain Protection PU	1 500 mm	1 450 mm	royal blue	1,2 kg

SAFE LOADING AND UNLOADING

RTH Stretcher Transporter 2018 R

The RTH hydraulic X-frame Stretcher transporter is based on our lifting tables, but has been modified specifically for loading and unloading rescue helicopters. The transporter is designed not only to accelerate the process of loading and unloading, but also to make it safer for both the patient and the operator.

The operator moves the transporter against the helicopter with the curved side that fits the helicopter shape, the height is then adjusted to match the height of the patient compartment, the transporter wheels are centrally locked and the stretcher can now be loaded or unloaded without the risk of getting stuck in gaps or other obstacles.

The extra wide wheelbase ensures that the transporter will not tilt over during loading and unloading or during patient transport, in particular on uneven terrain.

**max. load capacity
300 kg**

Transporter safety features

At the top end, an adjustable flip-up stop-plate prevents the stretcher from rolling off the table. Once adjusted, the stop-plate can be locked in place. These safety devices are available for all stretcher types commonly used with rescue helicopters.

The stop-plate is easily unlocked by pulling a latch.

If the stretcher is fitted with lock pins at the foot end, these will automatically be guided into the openings provided to prevent sideways sliding.

Vertical adjustment by foot pedal: raising the transporter from its lowest position (bed position) to helicopter loading height requires only a few pumping actions.

The stretcher transporter uses quality anti-static wheels with a 200 mm diameter and a 40 mm tread width. Directional wheel lock is standard feature of the model 2018 R

The solid rubber tires are always fully operational. The foot lever for the central locking is large and easy to operate.



The storage tray on the sub-frame is included as standard

**Stainless steel
stretcher table,
steel tube sub-frame,
white powder coating.**

SPECIFICATIONS

height dimensions to stretcher table level (excluding footrest)

	length	width total	width platform only	height max.	height min.	weight	load capacity max.
2018 R	2320 mm	750 mm	570 mm	1080 mm	730 mm	approx. 105 kg	300 kg

THE BASIC MODEL



2018 R

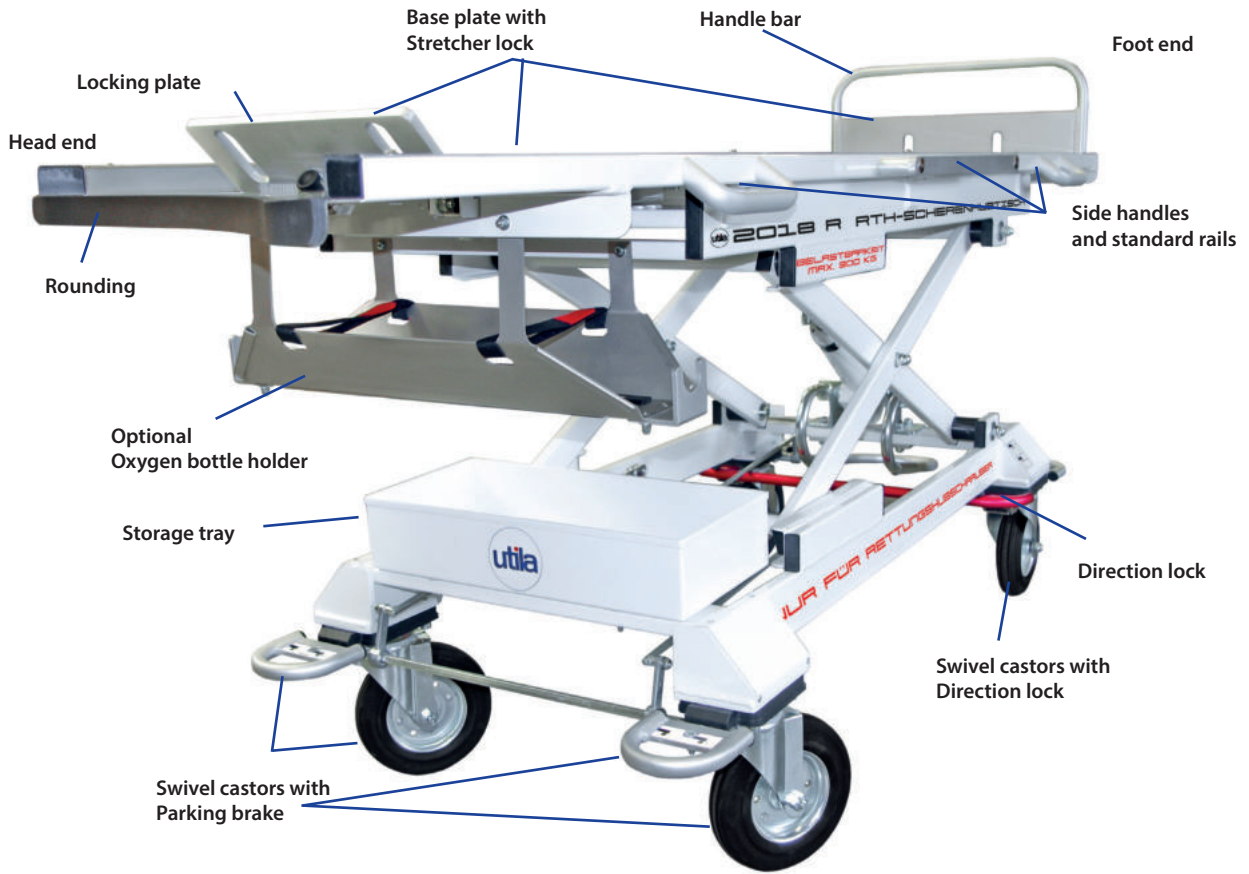

Parking brake control handle (on each wheel)



Height adjustment control handle



Direction lock also as retrofit kit 2018 NRS-R for RTH Stretcher transporter 2018

2018 R EQUIPMENT

2018 R

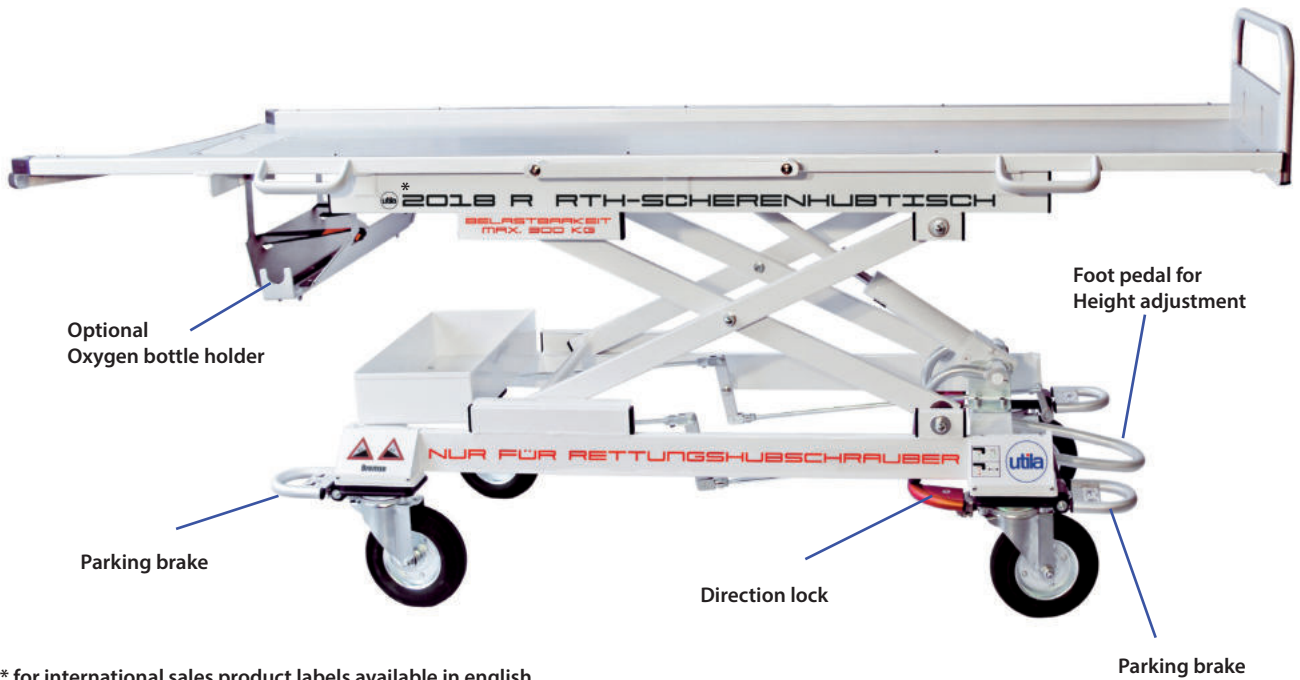

* for international sales product labels available in english



Optional: 2018 AW
Storage tray extra big



Head end with double-lip impact rubber and raised mounting plate

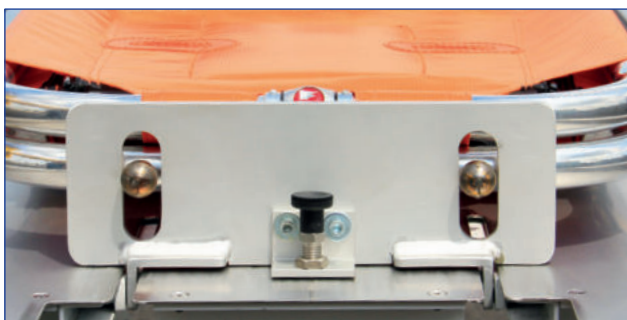

Stretcher 12-2 secured with the mounting plate



Optional: 2018 AFP
Locking plate at the foot end with foot pad

WE BRING COLOR INTO THE GAME



RAL colors

The frames of the utila carrying chairs and stretcher tables are powder-coated in white as standard. Upon request, you can also receive your product from us in all RAL colors.

A small surcharge will be charged for the color change.



2018 RH WITH SUSPENSION PATIENT POSITIONING

RTH Stretcher table

2018 RH



The RTH stretcher table 2018 RH is based on the 2018 R model, but is equipped with a stretcher mount with fully automatic air suspension.

Comfort for the patient

Known from the rescue service in ambulances and emergency ambulances. The fully automatic air suspension absorbs up to 80% of the incoming vibration energy, depending on the nature of the ground. As a result, the patient is optimally protected from vibrations or shocks, without the well-known nausea caused by large oscillation paths.

There is also no side inclination when cornering or nodding in the patient's head area when braking.

Fully automatic weight adjustment and optimal suspension of the patient's weight. Optimal combination of high quality stainless steel and light aluminum.

Easy maintenance, easy to clean.

Integrated compressor or in a hermetically sealed external box, 12 volts, 25 amps.



**2018 PPB
Push Pole Box for
Push Poles set 2018 PP**

optional storage box,
with fasteners

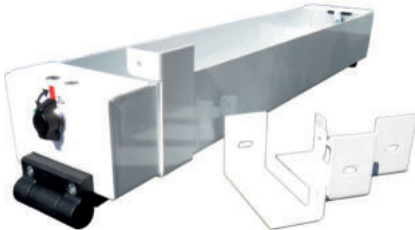

FEATURES

2018 RE



Switchable

If necessary, the drive unit can be switched on and, when not in use, without contact with the ground.



Retrofit

Also available as a retrofit kit for the 2018 R hydraulic X-frame Stretcher transporter.



Fast thrust

The drive unit starts up quickly and safely even under high loads.



One-button operation

Ergonomic handle with one-button operation and integrated LED display for system and battery status.



High contact pressure

Thanks to the high contact pressure with a compensation function for uneven surfaces, you always have optimal ground contact.

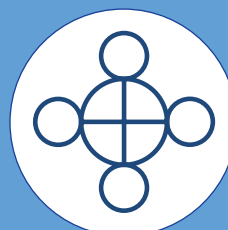

User friendliness

User-friendly and flexible vertical or horizontal installation of the hand control unit.

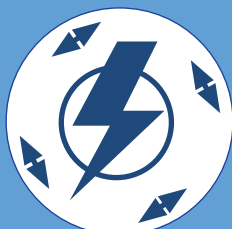

Safety-tested drive switch

Stepless speed regulation for forward and reverse running by means of a safety-tested drive switch.

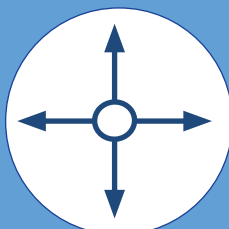

Increased driving stability

Increased driving stability in curves and when simply running straight ahead, especially on long routes.

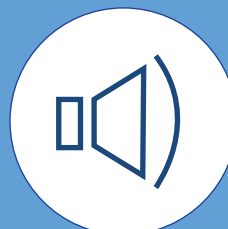

Quiet running noises

Low-noise rolling thanks to the special coated wheels.

2018 RE

e-DRIVE FLEX

Thrust max. 25 daN

The drive unit works like a fifth wheel and offers perfect directional stability even when using four swivel wheels.

The system is activated via the control unit by pressing the button on the handle. The drive unit lowers and is ready for use. The stepless speed regulation (forwards and backwards) enables optimal use.

The energy required is supplied by a powerful, rechargeable battery. You can choose between lithium-ion or lead-gel battery technology. The system is activated and deactivated with the push of a button. As soon as the drive unit is raised, the hydraulic X-frame Stretcher transporter has complete freedom of movement and can be maneuvered in tight spaces.

The housing of the drive unit is made of galvanized sheet steel. The robust construction also guarantees complete protection against splash water (IPX4).

The drive unit wheel is made of soft rubber that allows easy rolling and ensures a quiet working environment. The wheel also has shock-absorbing properties.

The operational safety of the e-Drive Flex control module has been tested and meets the requirements of the DIN EN 13849 standard.

e-Drive Electric drive Retrofit kit 2018 NRS-ED

For hydraulic X-frame Stretcher transporter 2018 R, with assembly parts. Attachment only possible in our factory.





iNTRAXX BRACKET ON UTILA STRETCHER TABLE

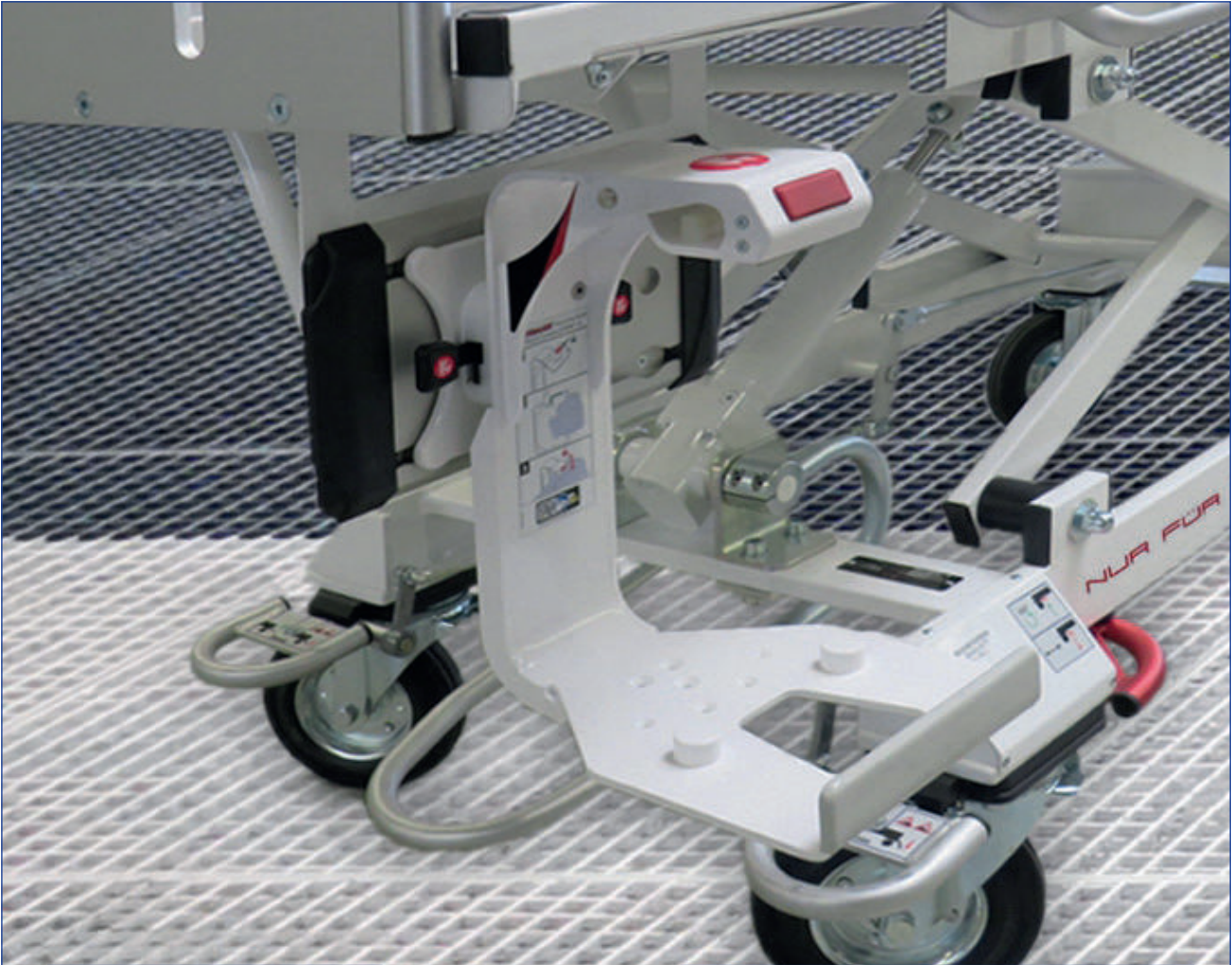

2018 IB
iNTRAXX Perforated rail
For Stretcher transporter 2018 R,
with attachment- and fastening parts

2018 AM ADAPTER MODULE FOR SIDE DOOR



2018 AM
Adapter module for H 135 helicopters
for loading and unloading through
the side door, with fastening parts

RTH STRETCHER TRANSPORTER 2018 R



Optional: 2018 AFP
Locking plate at the foot end with foot pad

EQUIPMENT RTH STRETCHER TRANSPORTER 2018 R



2018 SF Oxygen bottle holder

for Stretcher table 2018 R, with fastening parts



2018 AR Bumper-wheels set (4 pieces)

for Stretcher table 2018 R, with fastening parts



2018 GB Strap attachment set

(4 pieces) for attaching additional straps to the Stretcher table 2018 R, with two patient restraints and fastening parts



2018 FB Bellows frame cladding

for Stretcher table 2018 R, with fastening parts



2018 IB in|TRAXX Perforated rail

for Stretcher table 2018 R, with attachment- and fastening parts



2018 PP Push poles set (2 pieces)

for Stretcher table 2018 R, with fastening parts

MAINTENANCE AND SERVICE



MAINTENANCE AND SERVICE
ensure that your devices function properly.



PowerTraxx

